

INCH-POUND

MIL-PRF-28876/5E  
4 October 2004  
SUPERSEDING  
MIL-C-28876/5D  
9 July 1992

PERFORMANCE SPECIFICATION SHEET

CONNECTORS, FIBER OPTIC, CIRCULAR, RECEPTACLE STYLE,  
MULTIPLE REMOVABLE TERMINI, SCREW THREADS,  
WITH STRAIGHT BACKSHELL, ENVIRONMENT RESISTING

This specification is approved for use by all Departments  
and Agencies of the Department of Defense.

The requirements for acquiring fiber optic connectors described herein  
shall consist of this specification sheet and MIL-PRF-28876.

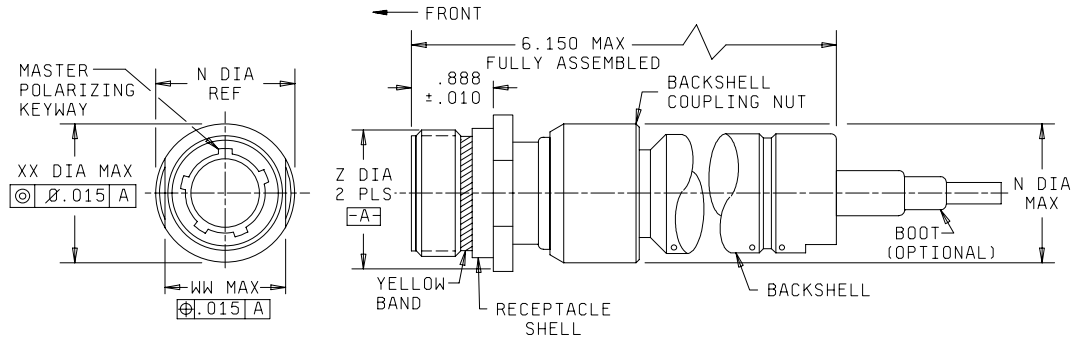

Inches	mm
.010	0.25
.015	0.38
.115	2.92
.888	22.56
6.150	156.21

FIGURE 1. Receptacle connector with straight backshell.

MIL-PRF-28876/5E

Shell size	N dia max	WW	XX	Z dia max	Insert figure 5/	Color band EIA-359
11	.960 (24.38)	.768 (19.51)	.963 (24.46)	.750 (19.05)	B-1	Yellow
13	1.085 (27.56)	.893 (22.68)	1.088 (27.63)	.875 (22.22)	B-2	Yellow
15	1.257 (31.93)	1.080 (27.43)	1.275 (32.38)	1.062 (26.97)	B-3 or B-4	Yellow
23	1.763 (44.78)	1.518 (38.56)	1.719 (43.66)	1.500 (38.10)	B-5 or B-6	Yellow

NOTES:

1. Dimensions are in inches.
2. Metric equivalents are given for general information only.
3. Dimensions apply to plated/finished part.
4. Metric equivalents (mm) are in parentheses.
5. For insert arrangement, see the indicated figure in appendix B of MIL-PRF-28876.

FIGURE 1. Receptacle connector with straight backshell - Continued.

REQUIREMENTS:

Dimensions and configurations: See figure 1 and MIL-PRF-28876 appendix A, figure A-2, figure A-6, and figure A-7.

Weight (without termini):

<u>Shell size</u>	<u>Weight (ounces, (gram)), maximum</u>
11	7.0 ounces (198.45 g)
13	8.0 ounces (226.8 g)
15	12.0 ounces (340.2 g)
23	24.0 ounces (680.4 g)

Fiber optic cable:

Cable diameter: .315 ± .020 inch (8.00 ± 0.51 mm), .425 ± .043 inch (10.80 ± 1.09 mm), or .817 ± .049 inch (20.75 ± 1.24 mm)

Protective caps: Each connector shall be supplied with protective caps over the front and rear portions of the connector.

Insert arrangement: See appendix B of MIL-PRF-28876 for desired shell size.

Termini: Style P (pin) or S (socket). See MIL-PRF-29504/1, MIL-PRF-29504/2, MIL-PRF-29504/12, MIL-PRF-29504/13, MIL-PRF-29504/14, and MIL-PRF-29504/15 (For dummy terminus, see MIL-PRF-29504/3).

MIL-PRF-28876/5E

Cleaning procedures: Each shipment of connectors shall include recommended cleaning procedures. The following wording or equivalent is recommended: "To clean, use lint free wipe dampened with alcohol and blow dry with air".

Shell polarization: 1 through 6 keyway positions. See MIL-PRF-28876 appendix A, figure A-3.

Marking:

PIN: Marked on flange of receptacle (see table I).

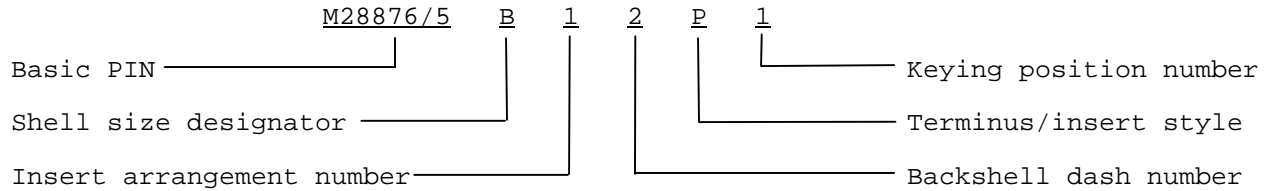

TABLE I. PIN designators.

Shell size	Shell size designator	Insert arrangement number	Terminus/Insert style	Key position	Maximum cable outer diameter in accordance with backshell dash number		
					-1	-2	-3
11	A	1	P or S	1, 2, 3, 4, 5, or 6	.250 (6.35)	.346 (8.79)	
13	B	1	P or S	1, 2, 3, 4, 5, or 6	.285 (7.24)	.346 (8.79)	.453 (11.50)
15	C	1 or 2	P or S	1, 2, 3, 4, 5, or 6	.500 (12.70)	.250 (6.35)	.375 (9.53)
23	F	1 or 2	P or S	1, 2, 3, 4, 5, or 6	.866 (22.00)	1.000 (25.40)	.600 (15.24)

Mating counterpart: Plug connectors specified in MIL-PRF-28876/6 through MIL-PRF-28876/9.

Installation and removal tools: As specified in NAVSEA drawing 6872813.

For qualified products listing, quality conformance, and periodic inspections, dummy termini shall be used in all unused cavities.

Patent notice: The Government does not have a royalty-free license under the following patents for the benefit of manufacturers of the item, either for the Government or for use in equipment to be delivered to the Government:

<u>Patent application no.</u>	<u>Patent expiration date</u>
US (65,032)	11/17/2004

NOTES:

Marginal notations are not used in this revision to identify changes with respect to the previous issue due to the extent of the changes.

Referenced documents. In addition to MIL-PRF-28876, this specification sheet references the following documents:

MIL-PRF-28876/6	MIL-PRF-28876/7	MIL-PRF-28876/8
MIL-PRF-28876/9	MIL-PRF-29504/1	MIL-PRF-29504/2
MIL-PRF-29504/3	MIL-PRF-29504/12	MIL-PRF-29504/13
MIL-PRF-29504/14	MIL-PRF-29504/15	
NAVSEA drawing 6872813		
EIA-359		

CONCLUDING MATERIAL

Custodians:

Army - CR  
Navy - SH  
Air Force - 11  
DLA - CC

Preparing activity:

Navy-SH

Agent:

DLA - CC

Review activities:

Navy - AS  
Air Force - 13, 19, 93, 99  
DIA - DI  
NASA - NA

(Project 6060-0144-05)

NOTE: The activities listed above were interested in this document on the date of this document. Since organizations and responsibilities can change, you should verify the currency of the information above using the ASSIST Online database at <http://www.dodssp.daps.mil/>.